

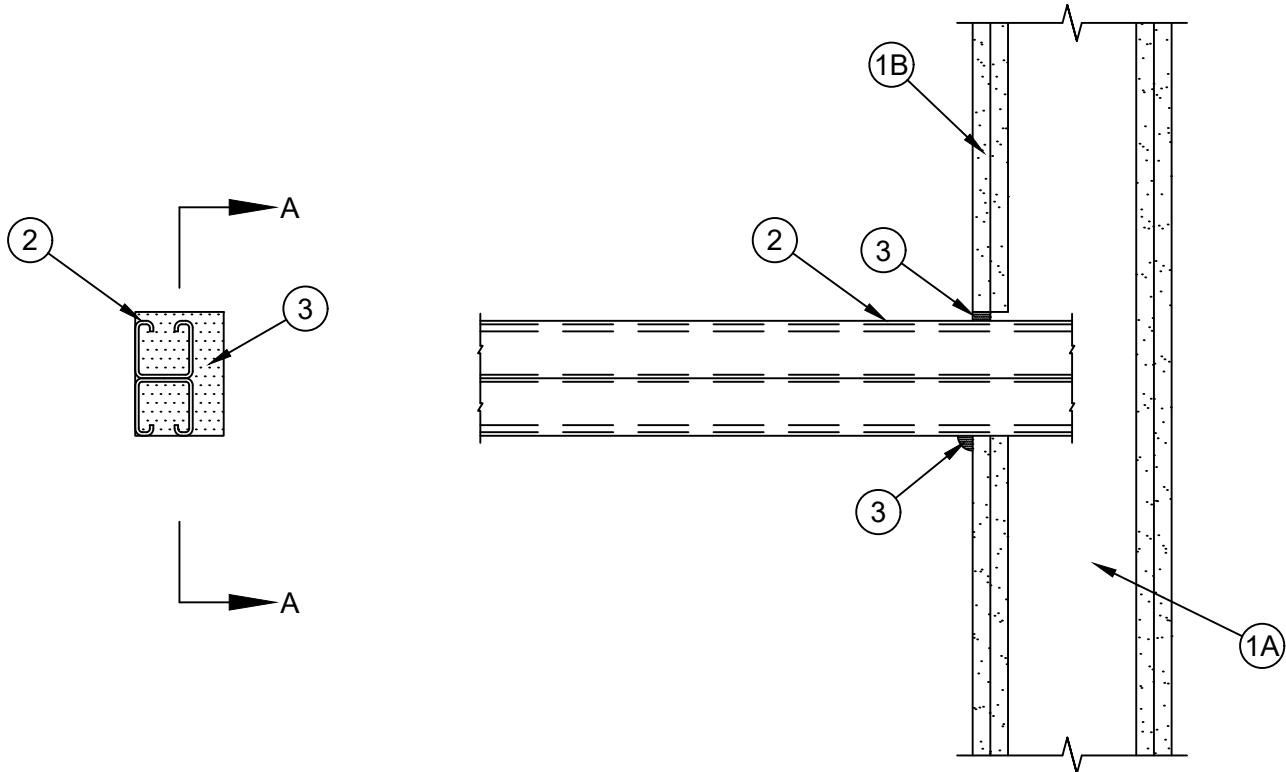

ANSI/UL1479 (ASTM E814)	CAN/ULC S115
F Ratings - 1 and 2 Hr (See Item 1)	F Ratings - 1 and 2 Hr (See Item 1)
T Ratings - 1 and 2 Hr (See Item 1)	FT Ratings - 1 and 2 Hr (See Item 1)
	FH Ratings - 1 and 2 Hr (See Item 1)
	FTH Ratings - 1 and 2 Hr (See Item 1)



SECTION A-A

1. **Wall Assembly** - The 1 or 2 hr fire-rated gypsum wallboard/stud wall assembly shall be constructed of the materials and in the manner specified in the individual U300, U400, V400 or W400 Series Wall and Partition Design in the UL Fire Resistance Directory and shall include the following construction features:
 - A. **Studs** - Wall framing may consist of either wood studs or steel channel studs. Wood studs to consist of nom 2 by 4 in. (51 by 102 mm) lumber spaced 16 in. (406 mm) OC. Steel studs to be min 3-1/2 in. (89 mm) wide and spaced max 24 in. (610 mm) OC.
 - B. **Gypsum Board*** - One or two layers of nom 5/8 in. (16 mm) thick gypsum board as specified in the individual Wall and Partition Design. Max area of opening is 8.75 sq in. (56 cm²) with a max dimension of 3-1/2 in. (89 mm). The opening cutout shall follow the contour of the penetrant when steel angle is used.

The hourly F, T, FT, FH and FTH Ratings of the firestop system are equal to the hourly fire rating of the wall assembly in which it is installed.



Specified Technologies Inc. 210 Evans Way Somerville, NJ 08876

Reproduced courtesy of Underwriters Laboratories, Inc.
Created or Revised: August 26, 2016



2. **Penetrant** - One metallic strut or steel angle to be installed either concentrically or eccentrically, penetrating wall assembly on one side of wall. The annular space between the penetrant and the periphery of opening shall be min 0 in. (point contact) to max 7/8 in. (22 mm). Penetrant shall be rigidly supported within the wall and on the penetrated side of the wall assembly. The following types and sizes of metallic struts or angles may be used:
- A. **Steel Strut** - Max 1-5/8 by 1-5/8 in. (41 by 41 mm) channel strut formed from min 0.105 in. (2.7 mm) thick galv or painted steel.
 - B. **Steel Strut** - Max 3-1/4 by 1-5/8 in. (83 by 41 mm) H strut formed from min 0.105 in. (2.7 mm) thick galv or painted steel.
 - C. **Steel Angle** - Max 2 by 2 in. (51 by 51 mm) by min 1/8 in. (3.2 mm) thick or max 3 by 3 in. (76 by 76 mm) by min 1/4 in. (6 mm) thick steel angle.
3. **Fill, Void or Cavity Materials* - Sealant** - Min 5/8 in. (16 mm) thickness of fill material applied within annulus, flush with surface of wall assembly. At point contact location, min 3/8 in. (10 mm) diam bead of fill material to be applied at the penetrant/gypsum board interface.

SPECIFIED TECHNOLOGIES INC - SpecSeal Series SSS Sealant, SpecSeal LCI Sealant or SpecSeal LC150 Sealant

*Indicates such products shall bear the UL or cUL Certification Mark for jurisdictions employing the UL or cUL Certification (such as Canada), respectively.



Specified Technologies Inc. 210 Evans Way Somerville, NJ 08876

Reproduced courtesy of Underwriters Laboratories, Inc.

Created or Revised: August 26, 2016

(800)992-1180 • (908)526-8000 • FAX (908)231-8415 • E-Mail:techserv@stifirestop.com • Website:www.stifirestop.com



W-L-7245
PAGE 2 OF 2