

System No. C-AJ-2772

F Rating - 2 Hr

T Rating - 2 Hr

L Rating At Ambient - Less Than 1 CFM/sq ft

L Rating At 400 F - Less Than 1 CFM/sq ft

W Rating - Class 1 (See Item 4B)

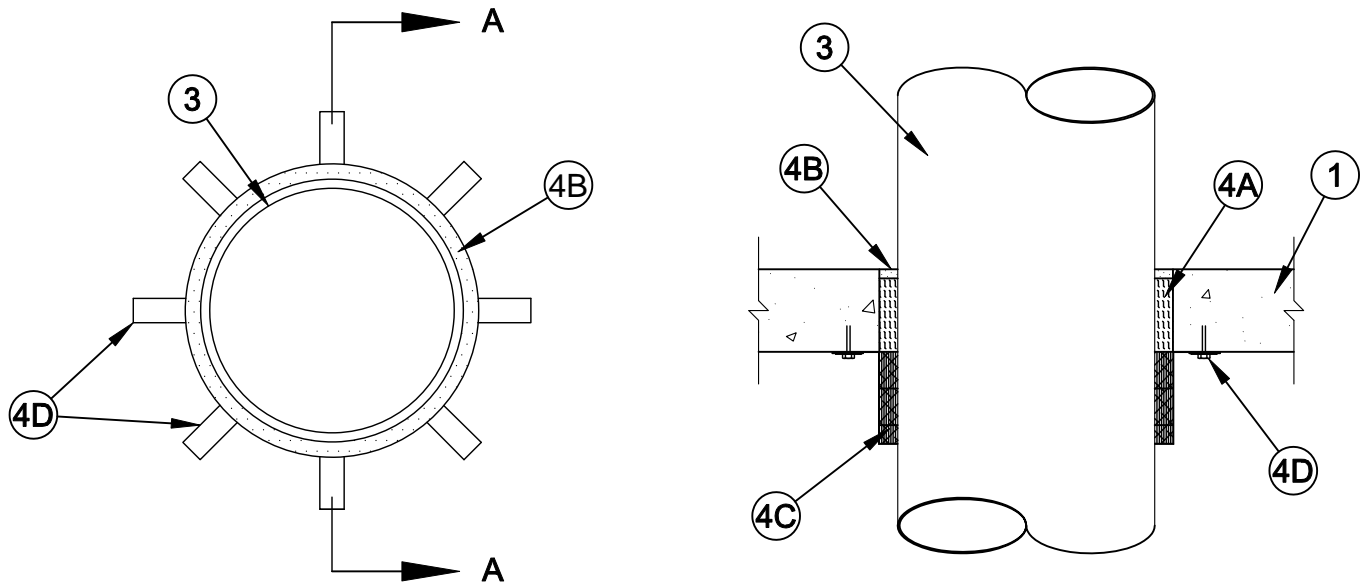

Section A-A

1. **Floor or Wall Assembly** - Min 4-1/2 in. (114 mm) thick reinforced lightweight or normal weight (100-150 pcf or 1600-2400 kg/m³) concrete. Wall may also be constructed of any UL Classified **Concrete Blocks***. Max diam of opening is 16 in. (406 mm).
See **Concrete Blocks** (CAZT) category in the Fire Resistance Directory for names of manufacturers.
2. **Steel Sleeve** - (Not Shown, Optional) - Nom 16 in. (406 mm) diam (or smaller) Schedule 10 (or heavier) steel pipe or nom 16 in. (406 mm) diam (or smaller) No. 24 GA (0.028 in. or 0.71 mm thick) sheet metal sleeve with square flange spot welded to the sleeve at approx mid-height and sized to be a min of 2 in. larger than the sleeve diam cast or grouted into floor or wall assembly, flush with floor or wall surfaces.
- 2A. **Nonmetallic Sleeve** - (Not Shown, Optional) - Nom 16 in. (406 mm) diam (or smaller) Schedule 40 polyvinyl chloride (PVC) pipe cast or grouted into floor or wall assembly, flush with floor or wall surfaces.
3. **Through Penetrants** - One nonmetallic pipe to be installed within the opening. A nom annular space of 1 in. (25 mm) is required within the firestop system. Pipe to be rigidly supported on both sides of floor or wall assembly. The following types and sizes of nonmetallic pipe may be used:
 - A. **Polyvinyl Chloride (PVC) Pipe** - Nom 14 in. (356 mm) diam (or smaller) Schedule 40 solid core PVC pipe for use in closed (process or supply) or vented (drain, waste or vent) piping systems.
 - B. **Chlorinated Polyvinyl Chloride (CPVC) Pipe** - Nom 14 in. (356 mm) diam (or smaller) Schedule 40 CPVC pipe for use in closed (process or supply) piping systems.



Specified Technologies Inc. 210 Evans Way Somerville, NJ 08876

Reproduced courtesy of Underwriters Laboratories, Inc.

Created or Revised: January 18, 2017

(800)992-1180 • (908)526-8000 • FAX (908)231-8415 • E-Mail:techserv@stifirestop.com • Website:www.stifirestop.com



C-AJ-2772
PAGE 1 OF 2

4. **Firestop System** - The firestop system shall consist of the following:

- A. **Packing Material** - Min 4 in. (102 mm) thickness of min 4 pcf (64 kg/m³) mineral wool batt insulation firmly packed into opening as a permanent form. Packing material to be recessed from top surface of floor or from both surfaces of wall as required to accommodate the required thickness of fill material.
- B. **Fill, Void or Cavity Material - Sealant** - Min 1/2 in. (13 mm) thickness of fill material applied within the annulus, flush with top surface of floor or with both surfaces of wall assembly.

SPECIFIED TECHNOLOGIES INC - SpecSeal Series SSS Sealant, SpecSeal LCI Sealant, SpecSeal SIL300 Sealant for floors or walls and SpecSeal SIL300SL Sealant for floors only.

W Rating applies only when SpecSeal SIL300 or SpecSeal SIL300SL Sealants are used.

- C. **Fill, Void or Cavity Materials* - Wrap Strip** - Nom 1/8 in. (3.2 mm) or 3/16 in. (4.8 mm) thick intumescent material faced on both sides with a plastic film, supplied in 2 in. (51 mm) wide strips. Two and one-half stacks (5 in. (127 mm) stack height) of wrap strips are individually or continuously wrapped around the through penetrant. Each stack shall consist of eight layers. When wrap strips are individually wrapped, ends of wrap strips shall be butted and held in place with tape. Butted ends in successive layers may be aligned or offset. The edge of the wrap strips shall abut the surface of the concrete floor or wall assembly. In floors, the two and one-half stacks of wrap strip are installed on the bottom side of the concrete floor. In wall assemblies, the two and one-half stacks of wrap strips are installed on each side of the concrete wall.

SPECIFIED TECHNOLOGIES INC - SpecSeal BLU Wrap Strip or SpecSeal BLU2 Wrap Strip

- D. **Steel Collar** - Collar fabricated from coils of precut 0.029 in. (0.7 mm) thick (No. 22 MSG) galv sheet steel available from wrap strip manufacturer. Collar shall be nom 5 in. (127 mm) deep with a min of six 1 in. (25 mm) wide by 2 in. (51 mm) long anchor tabs for securement to the concrete floor or wall. Retainer tabs, 3/4 in. (19 mm) wide tapering down to 1/4 in. (6 mm) wide and located opposite the anchor tabs, are folded 90 degrees toward through penetrant surface to maintain the annular space around wrap strips and through penetrant and to retain the wrap strips. Two steel collars wrapped around wrap strips and through penetrant with a min 1 in. (25 mm) wide overlap at the end of each collar along its perimeter joint with the adjacent steel collar. Steel collars tightened around wrap strips and through penetrant using min 1/2 in. (13 mm) wide by 0.028 in. (0.7 mm) thick stainless steel hose clamps located 1 in. (25 mm) and 4 in. (102 mm) from concrete surface. Collars secured to concrete surface with 1/4 in. (6 mm) diam by min 1-1/4 in. (32 mm) long steel concrete screws in conjunction with min 1 in. (25 mm) diam steel fender washers through each of a min of twelve symmetrically-located anchor tabs. As an alternate to the steel concrete screws, nom 1-1/4 in. (32 mm) long steel powder actuated fasteners provided with 3/4 in. (19 mm) diam steel washers may be used to secure anchor tabs.

* Indicates such products shall bear the UL or cUL Certification Mark for jurisdictions employing the UL or cUL Certification (such as Canada), respectively.



Specified Technologies Inc. 210 Evans Way Somerville, NJ 08876

Reproduced courtesy of Underwriters Laboratories, Inc.

Created or Revised: January 18, 2017

(800)992-1180 • (908)526-8000 • FAX (908)231-8415 • E-Mail:techserv@stifirestop.com • Website:www.stifirestop.com



C-AJ-2772
PAGE 2 OF 2