



System No. CW-D-2074

F Rating - 2 Hr

T Rating - 1/4 Hr

Linear Opening Width - 8 In. Max

L Rating At Ambient - Less Than 1 CFM/Lin Ft

L Rating At 400°F - Less Than 1 CFM/Lin Ft

Class II Movement Capabilities - 5% Vertical Shear (See Item 3)

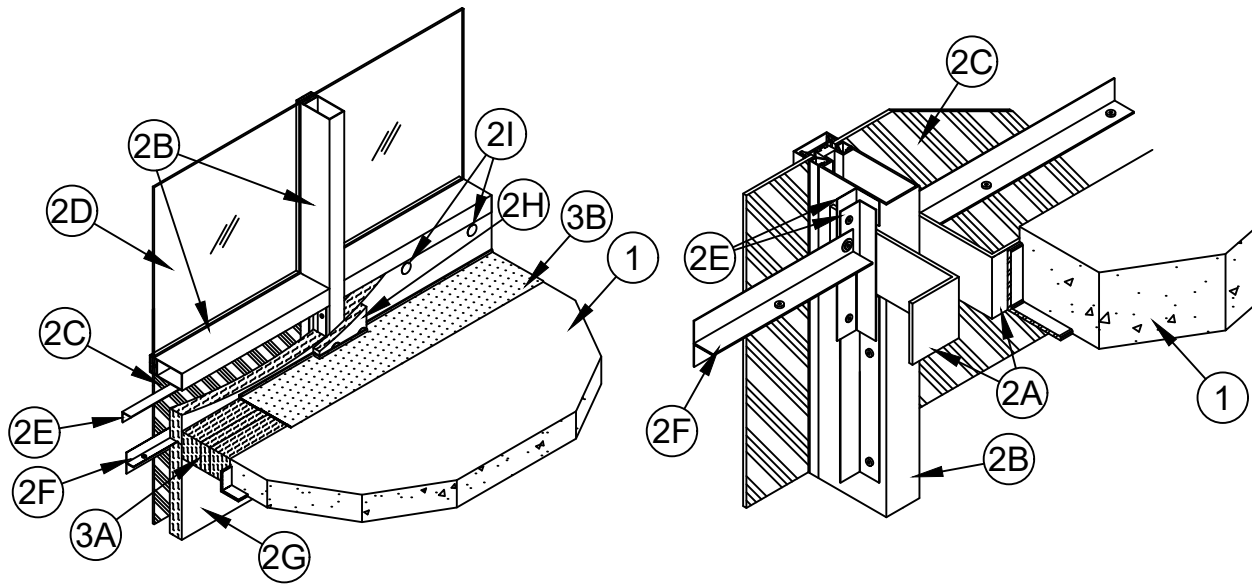

1. **Floor Assembly** - Min 4-1/2 in. (114 mm) thick reinforced lightweight or normal weight (100-150 pcf or 1600-2400 kg/m³) structural concrete. Perimeter of floor assembly to be provided with min 3 by 3 by 1/4 in. (76 by 76 by 6 mm) thick cast-in-place structural steel angle for weld-attachment of mullion mounting clips (Item 2A).
2. **Curtain Wall Assembly** - The curtain wall assembly shall incorporate the following construction features:
 - A. **Mullion Mounting Clips** - Min 4 in. (102 mm) long angles with one nom 4 in. (102 mm) leg for attachment to edge of floor assembly and with one leg approx 4 in. (102 mm) longer than distance to nearest face of mullion. Clips to be formed of min 1/4 in. (6 mm) thick steel. Clips welded to steel angle at edge of floor assembly (Item 1) on each side of vertical mullion (Item 2B) at each floor level. Each clip to be provided with elongated holes to accommodate designed amount of movement. Top edge of each clip to be recessed min 1/2 in. (13 mm) below top surface of floor.
 - B. **Framing** - The rectangular tubing mullions (vertical members) and transoms (horizontal members) shall be min 2-1/2 in. (64 mm) wide by 5 in. (127 mm) deep and shall be formed from min 0.085 in. (2.2 mm) thick aluminum. Mullions spaced max 60 in. (152 cm) OC and secured to mullion mounting clips (Item 2A) at each floor level with two 3/8-16 by 4 in. (102 mm) long hex head steel bolts in conjunction with Steel nuts and washers. Interior face of mullions to be max 8 in. (204 mm) from edge of floor assembly. Transoms to be spaced min 36 in. (91 cm) OC. The minimum height from the top of the floor to the bottom of the vision panel sill is 6 in. (152 mm).
 - C. **Spandrel Panels** - The spandrel panels shall consist of one of the following types:
 - a. **Glass Panels** - Nom 1/4 in. (6 mm) thick opaque heat-strengthened glass or nom 1 in. (25 mm) thick insulated glass units with two layers of nom 1/4 in. (6 mm) thick heat-strengthened glass separated by a 1/2 in. (25 mm) air space. Each panel secured in position with aluminum pressure plates in conjunction with glazing gaskets and steel screws.
 - b. **Aluminum Panels** - Nom 1/8 in. (3 mm) thick aluminum panels with 1/4 in. (6 mm) thick edges. Each panel secured in position with aluminum pressure plates in conjunction with gaskets and steel screws.
 - c. **Stone Panels** - Nom 1-3/16 in. (46 mm) thick polished granite spandrel panels with 1 in. (25 mm) thick gauged edges. Each panel secured in position with aluminum pressure plates in conjunction with gaskets and steel screws.

- d. **Metal Composite Panels** - Min 1 in. (25 mm) thick, comprised of 0.032 in. (0.8 mm) smooth aluminum exterior skin, 0.157 in. (4 mm) thick mineral fiber cement board exterior stabilizer, 5/8 in. (16 mm) thick Micore 300 mineral fiberboard insulation core, 0.157 in. (4 mm) thick mineral fiber cement board interior stabilizer, and a 0.032 in. (0.8 mm) smooth aluminum interior skin. Each panel secured in position with aluminum pressure plates in conjunction with glazing gaskets and steel screws or with silicone structural glazing.
- D. **Vision Panels** - Nom 1/4 in. (6 mm) thick transparent heat-strengthened glass or nom 1 in. (25 mm) thick insulated glass units with two layers of nom 1/4 in. (6 mm) thick transparent heat-strengthened glass separated by a 1/2 in. (25 mm) air space. Each panel secured in position with aluminum pressure plates in conjunction with glazing gaskets and steel screws.
- E. **Spandrel Panel Perimeter Angles** - Nom 1-1/2 by 1-1/2 in. (38 by 38 mm) No. 22 gauge (0.031 in. or 0.79 mm thick) galvanized steel angles installed around entire perimeter of each spandrel panel. Angles recessed from interior face of framing as necessary to accommodate thickness of curtain wall insulation (Item 2G). Angles cut to be discontinuous at mullion mounting clips (Item 2A). Angles screw-attached to mullions and transom along sides and top of each spandrel panel with No. 8 by 1 in. (25 mm) long self-drilling, self-tapping steel screws spaced max 12 in. (305 mm) OC. Angle along bottom of each spandrel panel to be screw-attached to leg of angle on mullion at each end without any direct attachment to transom. At mullion mounting clips, a length of steel angle shall be installed to bridge between the perimeter angles over the mullion mounting clip. The "bridge" shall be cut approx 6 in. (152 mm) longer than the clear space between angles and shall be secured to the perimeter angles with one No. 8 by 1 in. (25 mm) long steel screw at each end.
- F. **Stiffener Tee** - Two nom 1-1/2 by 1-1/2 in. (38 by 38 mm) No. 20 gauge (0.038 in. or 0.97 mm thick) galv steel angles secured together, back-to-back, to form stiffener tee for installation in each horizontal seam of the curtain wall insulation (Item 2G). The angle legs forming the stem of the tee shall be secured together using No. 8 by 1/2 in. (13 mm) long self-drilling, self-tapping steel screws spaced max 8 in. (204 mm) OC. The tee shall be installed with a clearance of 1/8 to 1/4 in. (3 to 6 mm) at each end and shall be screw-attached to the spandrel panel perimeter angles (Item 2E) with No. 10 by 3/4 in. (19 mm) long self-drilling, self-tapping steel screws, with steel washers, through two predrilled 1/4 in. (6 mm) diam holes at each end. One stiffener tee shall be located with its stem at an elevation 2 in. (51 mm) below the top plane of the floor at each floor level.
- G. **Curtain Wall Insulation*** - Min 2 in. (51 mm) thick mineral wool batt insulation, unfaced or faced on one side with aluminum foil/scrim vapor retarder, supplied in min 36 in. (914 cm) wide batts. Insulation batts to be installed with no vertical seams. Insulation panels tightly-fitted between vertical mullions and between the stem of the stiffener tee (Item 2F) and the transom, flush with the interior surface of framing. Insulation panels secured to spandrel panel perimeter angles with cup head weld pins (Item 2I) or 2-1/2 in. (64 mm) long steel screws with min 1-1/2 in. (38 mm) diameter galv steel clinch shields spaced max 12 in. (305 mm) OC. The horizontal seam between insulation panels shall be located 2 in. (51 mm) below the top plane of the floor at each floor level.

ROCKWOOL MALAYSIA SDN BHD - CurtainRock 80

ROCKWOOL - CurtainRock 80

- H. **Framing Covers - Curtain Wall Insulation*** - Min 8 in. (204 mm) wide strips cut from the same min 2 in. (51 mm) thick mineral wool batt insulation used for the curtain wall insulation (Item 2G). Framing covers to be centered over mullions and secured to the spandrel panel perimeter angles with cup head weld pins (Item 2I) or 4-1/2 in. (114 mm) long steel screws with min 1-1/2 in. (38 mm) diameter galv steel clinch shields spaced max 12 in. (305 mm) OC. Where more than one spandrel panel (Item 2C) occurs between vertically separated vision panels, the horizontal transom between spandrel panels shall also be covered with an 8 in. (204 mm) wide framing cover in the same manner as on the vertical mullions. Framing covers on mullions to abut the mineral wool batt safin material (Item 3A) above and below floor.

ROCKWOOL MALAYSIA SDN BHD - CurtainRock 80

ROCKWOOL - CurtainRock 80

- I. **Weld Pin** - In lieu of steel screws, No. 12 gauge (2 mm diam) galv steel weld pin with nom 1-3/16 in. (30 mm) diam galv steel cup head. Cup head weld pins provided in two lengths. One length to be equal to thickness of curtain wall insulation (Item 2G) and second length to be equal to thickness of curtain wall insulation plus thickness of framing cover (Item 2H). Cup head weld pins inserted through curtain wall insulation and mullion covers and welded to spandrel panel perimeter angles max 12 in. (305 mm) OC.



Specified Technologies Inc. 210 Evans Way Somerville, NJ 08876

Reproduced courtesy of Underwriters Laboratories, Inc.
Created or Revised: October 22, 2018

(800)992-1180 • (908)526-8000 • FAX (908)231-8415 • E-Mail:techserv@stifrestop.com • Website:www.stifrestop.com



CW-D-2074
PAGE 2 OF 3

3. **Safing System** - Max separation between edge of floor assembly and face of framing members (at time of installation) is 8 in. (204 mm). The safing system is designed to accommodate vertical shear movement up to a max of 5 percent of its installed width. The safing system shall incorporate the following construction features:

A. **Forming Material*** - Nom 4 pcf (64 kg/m³) density mineral wool batt insulation. Batt sections cut to a min 4 in. (102 mm) width and stacked to a thickness which is min 25 percent greater than the width of linear gap between the curtain wall insulation and the edge of the concrete floor slab. The stacked forming material is compressed 20 percent in the thickness direction and inserted cut-edge-first into the linear gap such that its top surface is flush with the top surface of the floor assembly. A max of one tightly-butted seam is permitted between mullions. Additional pieces of forming material to be friction-fit into spaces between mullion mounting clips at each mullion location.

ROCKWOOL MALAYSIA SDN BHD - SAFE

ROCKWOOL - SAFE

B. **Fill, Void or Cavity Material*** - Min 1/8 in. (3 mm) wet thickness (min 1/16 in. or 1.6 mm dry thickness) of fill material spray-applied over top of forming material and lapping min 1/2 in. (13 mm) onto the top surface of the floor and onto the curtain wall insulation and framing covers. When SpecSeal Fast Tack Spray is used, wet and dry thickness of spray is min 5/64 in. (2 mm).

SPECIFIED TECHNOLOGIES INC - SpecSeal AS200 Elastomeric Spray, SpecSeal Safing Spray or SpecSeal Fast Tack Spray

* Indicates such products shall bear the UL or cUL Certification Mark for jurisdictions employing the UL or cUL Certification (such as Canada), respectively.



Specified Technologies Inc. 210 Evans Way Somerville, NJ 08876

Reproduced courtesy of Underwriters Laboratories, Inc.

Created or Revised: October 22, 2018

(800)992-1180 • (908)526-8000 • FAX (908)231-8415 • E-Mail:techserv@stifirestop.com • Website:www.stifirestop.com



CW-D-2074
PAGE 3 OF 3