

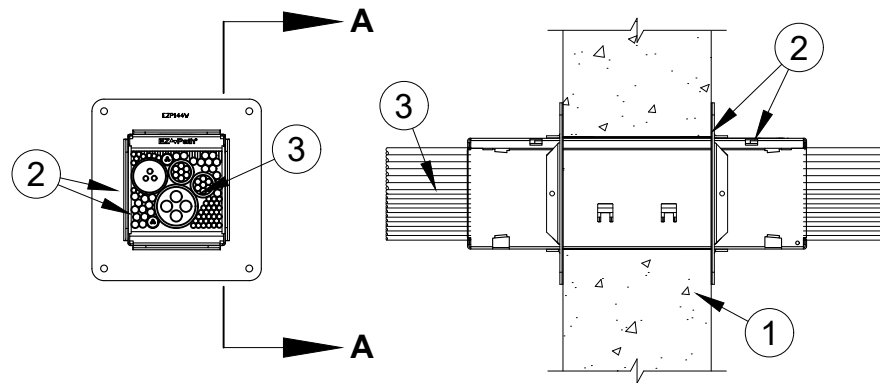

| | |
|--|---|
| ANSI/UL1479 (ASTM E814) | CAN/ULC S115 |
| F Rating - 2 Hr | F Rating - 2 Hr |
| T Ratings - 0, 1/2, 3/4, 1, 1-1/2 and 2 Hr (See Item 3) | FT Ratings - 0, 1/2, 3/4, 1, 1-1/2 and 2 Hr (See Item 3) |
| L Rating At Ambient -Less than 1 to 2.3 CFM/Device Module (See Item 2) | FH Rating - 2 Hr |
| L Rating At 400 F -Less than 1 to 2.3 CFM/Device Module (See Item 2) | FTH Ratings - 1, 1-1/2 and 2 Hr (See Item 3) |
| | L Rating At Ambient - Less than 1 to 2.3 CFM/Device Module (See Item 2) |
| | L Rating At 400 F - Less than 1 to 2.3 CFM/Device Module (See Item 2) |



Section A-A

- Wall Assembly** - Min 5 in. (127 mm) thick reinforced lightweight or normal weight (100-150 pcf or 1600-2400 kg/m³) concrete wall. Wall may also be constructed of any UL Classified **Concrete Blocks***. Opening in wall to be 6 in. (152 mm) in diam or max 4-1/8 in. (105 mm) by 4-3/4 in. (121 mm). See **Concrete Blocks** (CAZT) category in the Fire Resistance Directory for names of manufacturers.
- Firestop Device*** - The firestop device module consists of a 4 by 4-5/8 by 14 in. (102 by 118 by 356 mm) long galv steel tube with an intumescent material lining. Firestop device module to be installed in accordance with the accompanying installation instructions. The space between the firestop device and the periphery of the opening shall be min 0 in. (point contact) to max 1/4 in. (6 mm). Firestop device module secured in place by means of solid or split steel wall plates installed with gasketing material supplied with product. Steel wall plates installed on both sides of wall and secured to each device by means of steel screws provided with device. Firestop device module is to be installed with ends projecting an equal distance beyond each surface of the wall assembly. The L Ratings vary according to whether the device module is blank (no cables) or loaded (with cables) and which cable type and size is used, as tabulated below:

| Device | Cable Type | L-Rating (CFM) | |
|---------|------------|----------------|-------------|
| | | Ambient | 400 °F |
| 0% | - | Less Than 1 | Less Than 1 |
| 1-25% | 4A-4I | 1.5 | 1.5 |
| 26-50% | 4A-4I | 2.3 | 2.3 |
| 51-75% | 4A-4I | 2.3 | 2.3 |
| 76-100% | 4A-4I | 2.3 | 2.3 |

SPECIFIED TECHNOLOGIES INC - EZ PATH Series 44+ Fire Rated Pathway



Specified Technologies Inc. 210 Evans Way Somerville, NJ 08876

Reproduced courtesy of Underwriters Laboratories, Inc.
Created or Revised: April 14, 2016



2A. **Firestop Device* - Extension Module** - (Optional, Not Shown) - Module attached to ends of firestop device (Item 2) to increase its length to facilitate installation in thicker walls. Each module consists of a 4 by 4-5/8 by 6 in. (102 by 118 by 152 mm) long galv steel tube with an intumescent material lining. Extension module to be installed in accordance with the accompanying installation instructions. When module is used, firestop device (Item 2) and extension module secured in place by means of steel plates installed with gasketing material supplied with product. Steel plates installed on both sides of wall and secured to each device or extension module by means of steel set screws provided with plates. Firestop device and extension module assembly to be installed with ends projecting an equal distance beyond each surface of the wall assembly.

SPECIFIED TECHNOLOGIES INC - EZ PATH Series 44+ Extension

3. **Cables** - Cables may represent a 0 to max 100 percent visual fill within the loading area for the firestop device module. Cables to be rigidly supported on both sides of the wall assembly. Any combination of the following types of cables may be used:
- A. Max 400 pair No. 24 AWG (or smaller) copper conductor telecommunication cable with polyvinyl chloride (PVC) or plenum-rated jacketing and insulation.
 - B. Max 750 kcmil single copper conductor power cable with XLPE jacket and insulation
 - C. Max 7/C No. 12 AWG copper conductor control cable with PVC or XLPE jacket and insulation.
 - D. Max 3/C No. 2/0 AWG metal clad or armored cable with steel or aluminum jacket.
 - E. Max 3/C No. 8 AWG NM cable (Romex) with PVC insulation and jacket.
 - F. Max four pair No. 22 AWG (or smaller) copper conductor data cable with PVC or plenum rated jacketing and insulation.
 - G. Coaxial cable with fluorinated ethylene or PVC insulation and jacketing having a max diam of 5/8 in. (16 mm).
 - H. Optical fiber cable with PVC or polyethylene (PE) jacket and insulation and having a max diam of 5/8 in. (16 mm).
 - I. Max RG6/U coaxial cable with fluorinated ethylene, polyethylene (PE), PVC or plenum rated jacketing and insulation.

For the Series 44+ firestop device and when Item 3A, 3B, 3C, 3D, 3E or 3I is used, the T, FT and FTH Ratings are 1 hr. When Item 3F or 3G is used, the T, FT and FTH Ratings are 1-1/2 Hr. When Item 3H is used, the T, FT and FTH Ratings are 2 Hr. When device is empty, the T, FT and FTH Ratings are 1-1/2 Hr.

+Bearing the UL Listing Mark

*** Indicates such products shall bear the UL or cUL Certification Mark for jurisdictions employing the UL or cUL Certification (such as Canada), respectively.**



Specified Technologies Inc. 210 Evans Way Somerville, NJ 08876

Reproduced courtesy of Underwriters Laboratories, Inc.
Created or Revised: April 14, 2016

(800)992-1180 • (908)526-8000 • FAX (908)231-8415 • E-Mail:techserv@stifirestop.com • Website:www.stifirestop.com



W-J-3180
PAGE 2 OF 2