

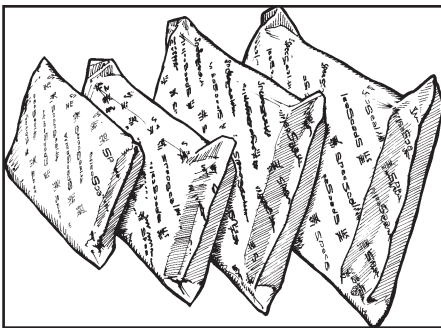

# SERIES SSB FIRESTOP PILLOWS

## APPLICATIONS

SpecSeal® Firestop Pillows are designed for firestopping medium to large openings containing various penetrating items such as pipes, conduits, cables, insulated metal pipes, bus ducts and HVAC ducts. Pillows are particularly well suited for applications involving data, communications, power or control cables, innerducts and cable trays. This method of sealing offers easy retrofitting of cable installations without the need to damage the firestop seal. Difficult applications such as one-sided shaft wall installations and other applications where access is restricted to one side of the assembly may be easily firestopped with this material.



## PRODUCT DESCRIPTION

SpecSeal® Firestop Pillows are through-penetration firestop products resembling small cushions or soft bricks. These intumescent and highly resilient pillows are installed in openings by compressing and stacking into the opening in a brick-like fashion.

SpecSeal® Firestop Pillows consist of a mineral fiber core material sealed with a water-resistant intumescent membrane. This coated core material is then heat-sealed in a tough, nonirritating, fire-retardant poly bag.

### FEATURES

- **Intumescent:** Expands in all directions for a tough, tight seal.
- **Reinstallable** for easy retrofitting of cables.
- **Lightweight** for ease of installation. Easier wire screen requirements.
- **Heat-Sealed Poly Bag:** Strong & durable. No sewn seams to unravel or tear. No irritating fiberglass.
- **Monolithic Encapsulated Core:** No loose fill!
- **No Special Tools Required!**
- **Superior Air Leakage Ratings!**

## PERFORMANCE

SSB Pillows are the basis for systems that meet the exacting criteria of ASTM E814 (UL1479) as well as the time-temperature requirements of ASTM E119 (UL263). Tested systems will provide up to three-hour rating for penetrations through concrete, CMU, or concrete tilt-up walls, as well as concrete or concrete over steel deck floors. Additional systems have been tested up to three hours in gypsum board walls.

**AIR LEAKAGE:** Tests conducted by Underwriters Laboratories for air leakage at ambient and elevated temperatures (400°F (204°C)) indicate that properly installed pillows seal penetrations virtually airtight.



SpecSeal® SSB Firestop Pillows  
 FILL, VOID OR CAVITY MATERIAL. CERTIFIED FOR USE IN  
 THROUGH-PENETRATION FIRESTOP SYSTEMS SEE UL ONLINE  
 CERTIFICATIONS DIRECTORY



## PHYSICAL PROPERTIES

See Table A

## SPECIFICATIONS

The firestopping system shall utilize an intumescent pillow heat sealed in a fire-retardant poly bag. The firestop pillow shall consist of a monolithic (one piece) core that is encapsulated on all sides by a flexible intumescent coating and shall not contain any loose fiber fill. The pillow shall be UL Classified and/or FM Systems Approved and tested to the requirements of ASTM E814 (UL1479).

### SPECIFIED DIVISIONS

|      |    |       |   |
|------|----|-------|---|
| DIV. | 7  | 07840 | Through-Penetration Firestopping                            |
| DIV. | 13 | 13900 | Special Construction Fire Suppression & Supervisory Systems |
| DIV. | 15 | 15250 | Mechanical Insulation – Fire Protection                     |
| DIV. | 16 | 16050 | Basic Electrical Materials & Methods                        |

**Table A:  
 PHYSICAL PROPERTIES**

|   |  |
|---|--|
| <b>Product Name</b>                                 | SSB Series<br>Firestop Pillows                             |
| <b>Storage Temp.:</b>                               | Less than 120°F (49°C)                                     |
| <b>Color:</b>                                       | Red  |
| <b>Nom. Density:</b>                                | 4 PCF (53 kg/m <sup>3</sup> )                              |
| <b>In-Service Temp:</b>                             | ≤130°F (54°C)  |
| <b>Flammability*:</b>                               | V-0  |
| <b>Compression**:</b>                               | 25% - 33%  |
| <b>Air Leakage:</b>                                 | Less than 1 CFM/sq ft                                      |
| <b>(L Rating):</b>                                  | UL1479 (Pillows Only)                                      |
| <b>VOC Content***:</b>                              | 0.00 lbs/gal (0.0 g/l)                                     |
| <b>STC Rating:</b>                                  | 60<br>(Relates to specific construction)<br>(ASTM E 90-04) |
| <b>Shelf Life:</b>                                  | No Limit   |
| * Outer poly bag.                                   |  |
| ** As installed.                                    |  |
| ***ASTM D 3960 and EPA Federal Reference Method 24. |  |



## INSTALLATION INSTRUCTIONS

**GENERAL:** Inspect areas to be protected. Remove any sharp edges or protruding wires or ties that could damage poly bags. Arrange cables (if possible) to present a smooth and even surface. Eliminate large voids by filling with SpecSeal® Firestop Putty at egress from floor or wall surfaces.  
**NOTE:** Do not cut or open outer poly bag.

Calculate pillow requirements in square inches in advance of installation as an indicator of the proper installed volume and compression. See Estimation Table for instructions concerning proper estimation techniques.

**SYSTEM SELECTION:** Consult UL® Fire Resistance Directory, STI Product & Application Guide, or drawings provided by the manufacturer for specific details concerning installation design and requirements.

**WIRE MESH:** Although not generally required, some installations may require the installation of wire mesh as either an integral component of the system or as an option to facilitate installation. When necessary, wound 20 AWG galvanized steel 1" (25 mm) diamond shaped mesh (e.g. poultry screen) is recommended. Do not use soldered mesh or wire cloth. Secure wire mesh to wall or floor surfaces using steel fasteners and fender washers as required by the particular system chosen for use.

**INSTALLATION OF PILLOWS:** All pillow sizes are 9" (229 mm) long. This dimension is referred to as the length. Width and thickness varies dependent upon the pillow chosen for use for the specific application.

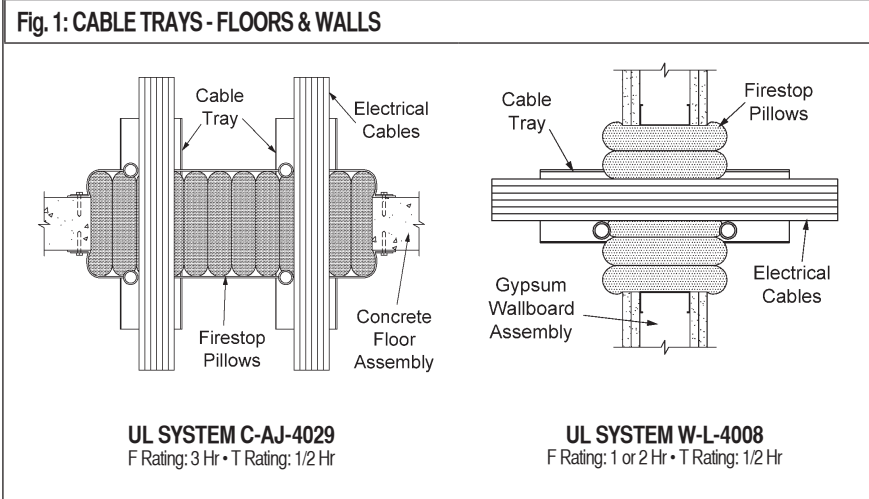

**Table B: PRODUCT ESTIMATION INFORMATION**

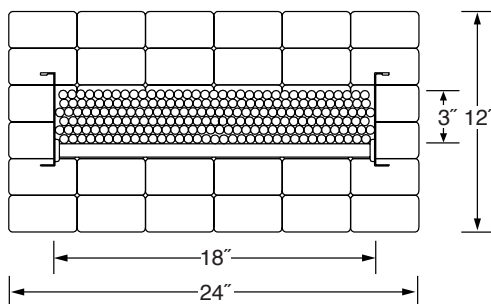

| NOMINAL CROSS-SECTIONAL AREA OF PILLOWS |                      |                      |                      |                      |
|---|----------------------|----------------------|----------------------|----------------------|
| Cat. No.                                | SSB14                | SSB24                | SSB26                | SSB36                |
| Nom. Dim <sup>a</sup>                   | 1" x 4"              | 2" x 4"              | 2" x 6"              | 3" x 6"              |
| (cm)                                    | 2.54 x 10.2          | 5.1 x 10.2           | 5.1 x 15.24          | 7.6 x 15.24          |
| Nom. Area <sup>b</sup>                  | 4 in <sup>2</sup>    | 8 in <sup>2</sup>    | 12 in <sup>2</sup>   | 18 in <sup>2</sup>   |
| (cm)                                    | 25.8 cm <sup>2</sup> | 51.6 cm <sup>2</sup> | 77.4 cm <sup>2</sup> | 116 cm <sup>2</sup>  |
| Effective Yield <sup>c</sup>            | 2.9 in <sup>2</sup>  | 5.7 in <sup>2</sup>  | 8.6 in <sup>2</sup>  | 12.9 in <sup>2</sup> |
| (cm)                                    | 18.7 cm <sup>2</sup> | 36.8 cm <sup>2</sup> | 55.5 cm <sup>2</sup> | 83.2 cm <sup>2</sup> |

NOTES: PILLOW LENGTH = 9" (22.9cm)

<sup>a</sup>Nom dimensions (uncompressed)

<sup>b</sup>Cross-sectional area (uncompressed)

<sup>c</sup>Cross-sectional area (compressed)

### CALCULATING PILLOW REQUIREMENT

Measure the size of the opening to be sealed and calculate the total area of the opening in square inches. Measure and calculate the approximate area occupied by the penetrants. Calculate the net area to be sealed by subtracting the area occupied by the penetrants from the total area of the opening. To allow for the required compression of the pillows, multiply the net area by 1.4. This will provide a compression factor of 29%.

In the example shown above, the opening is 12" x 24" with an 18" wide tray. The cable depth in the tray is about 3". The area of the opening is 12 x 24 = 288 sq. in. The approximate area of the cables is 3 x 18 = 54 sq. in. Subtracting the area of the cables from the total area of the opening yields a net area of 234 sq. in. 234 x 1.4 = approx. 328 sq. in. to be filled by pillows. Using the table above to determine the nominal area of the various pillows, we can determine that approximately 28 (328 ÷ 12) SSB26 pillows would be required. The number of pillows required will of course vary by the size of the pillow being utilized. Generally, a small percentage of smaller pillows will be required along with the larger ones. A test opening of this size utilized 24 SSB26 pillows, along with 4 SSB24's and 4 SSB14's.

## INSTALLATION OF SPECSEAL PILLOWS

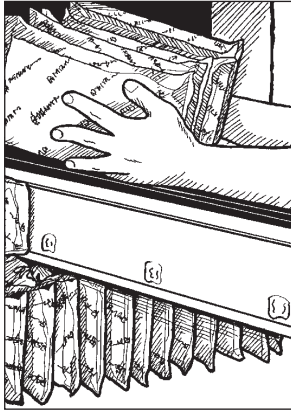

1. Install pillows lengthwise through the opening. Pillows may be stacked and installed in groups as shown above.

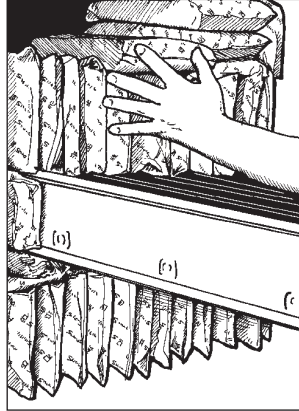

2. Pillows installed on edge will follow the contour of the cables more closely. Pillows may be installed laying flat as shown at the top of the penetration or on edge.



3. Smaller pillows are used to pack the smaller voids such as the space created by the tray rail. SpecSeal® Firestop Putty is used to seal any small voids at the cable line.

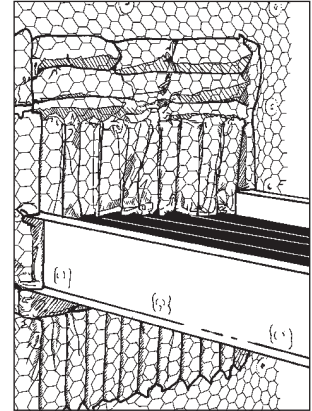

4. Check to make sure pillows are tightly compressed and all voids are closed. (If required by design, attach mesh using suitable fasteners to cover pillows and prevent un-intentional or unauthorized removal).

## (INSTALLATION CONT.)

Unless otherwise specified within the individual UL System, pillows are installed lengthwise through the opening to form a 9" (228mm) seal. Install pillows within opening such that the ends project an equal distance from the approximate centerline of the floor or wall. Orientation of the pillows may be either with the width (wide side) parallel or perpendicular to penetrants. In cable tray applications where the cable face is uneven, pillows installed perpendicular to cables may form a tighter, more uniform seal. Install all pillows in a manner that ensures that they will be compressed (in both width and thickness) to form tight seams between the bags with no voids or gaps. Smaller pillows may be used to seal appropriately sized gaps that may occur above or below cable tray rungs, etc. Pack SpecSeal Firestop Putty into any small voids between cables and pillows, tray and cables, tray and bags, bag to bag, or bag to wall or floor interface. Complete installation by installing wire mesh on remaining wall or floor surface as required by design system being used. Generally, a 2"-3" (50-75mm) overlap of the surrounding wall or floor surface is required. Install fasteners on 6" (152 mm) centers. A steel fender washer of sufficient diameter to completely overlap the opening through the mesh is required. The mesh may be fastened to concrete floors or concrete or CMU walls using suitable steel anchors (e.g. Tapcon® Fasteners by ITW Ramset). For hollow gypsum wallboard assemblies, attach mesh to the face of the wall using self-tapping, gypsum wallboard screws into the framing members surrounding the opening.

### USING SPECSEAL MORTAR TO REDUCE OPENING SIZE

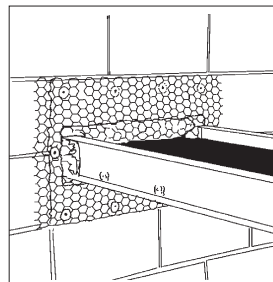
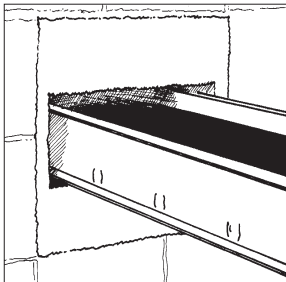

In the two photos shown above, SpecSeal Firestop Mortar has been installed around the cable tray as an economical void filler. In preparation, foam board forms are used to create the opening around the tray and to prevent leakage of the mortar from the wall cavity. After the mortar has dried, the forms are removed and the pillows are installed. Consult UL System No. C-AJ-4030 as well as the SpecSeal Firestop Mortar Product Data sheet for additional installation information.

### BOTTOM-UP INSTALLATIONS!

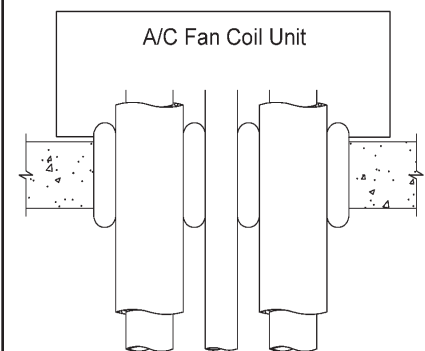

Pillows can be used to seal openings that are accessible only from the bottom as in this typical fan-coil installation. See UL System No. C-AJ-8052.

## MAINTENANCE

**INSPECTION:** Installations should be inspected periodically for subsequent damage. Replace any damaged pillows.

**RETROFIT:** Cables may be added or replaced in previously sealed openings by removing the mesh and removing and replacing pillows as required. **DO NOT WEAVE CABLES THROUGH WIRE MESH!** Doing so may interfere with subsequent efforts to add or remove cables and may pose a safety hazard. Reinstall pillows and putty as required and then replace wire mesh.

**NOTE:** Removal of cables may require the installation of additional pillows to fill the void created by removing the cables. Inspect pillows for excess compression. SpecSeal Firestop Pillows are designed to be very durable and highly resilient. Excessive handling or abuse may permanently compress the pillows. If pillows are too thin to apply pressure within the seal when installed, replace thin pillows or add additional new pillows as required.



## TECHNICAL SERVICE

Specified Technologies Inc. provides toll free technical support to assist in product selection and appropriate installation design. UL Systems, Material Safety Data Sheets and other technical information is available at the Technical Library at [www.stifirestop.com](http://www.stifirestop.com) or through

## PRECAUTIONARY INFORMATION

Consult Material Safety Data Sheet for additional information on the safe handling and disposal of this material. Avoid damaging poly outer bag. Do not use damaged pillows.

## AVAILABILITY

SpecSeal® Firestop Pillows are produced in four convenient sizes and are available from authorized distributors. Consult factory for the names and locations of the nearest sales representatives or distributors.

**RETROFITTING**

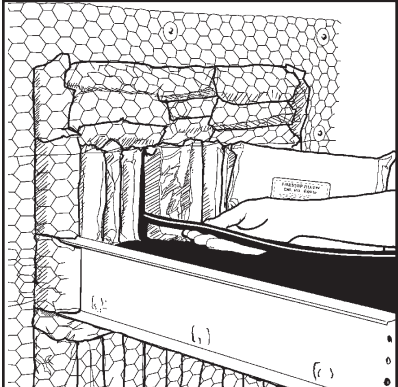

1. Cut & fold back wire mesh in the area to be modified.
2. Remove only the pillow or pillows necessary to accommodate the change.
3. Modify cables.
4. Reinstall pillow(s).
5. Re-close wire mesh and fasten wire mesh together using 20 gauge steel wire.

### TABLE C: ORDERING INFORMATION

| CAT. NO. | DIMENSIONS                       | CASE QUAN. |
|----------|----------------------------------|------------|
| SSB14    | 1" x 4" x 9" (25 x 101 x 229 mm) | 20         |
| SSB24    | 2" x 4" x 9" (50 x 101 x 225 mm) | 10         |
| SSB26    | 2" x 6" x 9" (50 x 152 x 225 mm) | 22         |
| SSB36    | 3" x 6" x 9" (76 x 152 x 225 mm) | 16         |

#### Additional SpecSeal Products...

##### SSP Firestop Putty

Available both in bar form and in pads, putty provides easy retrofit for through-penetrations and economical protection for electrical boxes.

##### Firestop Mortar

Lightweight, versatile and economical! The best choice for large or complex installations.

##### Intumescent Wrap Strips

Two grades of intumescent wrap strips provide an unmatched combination of flexibility, economy, and expansion (up to 30X). Systems for plastic pipes including FR Polypropylene up to 8" trade size!

## CITY OF NEW YORK MEA 39-96-M

**IMPORTANT NOTICE:** All statements, technical information, and recommendations contained herein are based upon testing believed to be reliable, but the accuracy and completeness thereof is not guaranteed.

**LIMITED WARRANTY:** STI warrants that its products will be free of defects for one year from the date of purchase. In the event a product does not conform to this warranty, the sole and exclusive remedy is, at STI's option, replacement of the product or refund of the purchase price. The warranty provided herein shall be void and of no effect in the event that the product is not installed in accordance with STI's published instructions, listed systems and applicable building and safety codes. THIS WARRANTY IS IN LIEU OF ALL OTHER REPRESENTATIONS AND EXPRESSED OR IMPLIED WARRANTIES (including the implied warranties of merchantability or fitness for a particular use) AND UNDER NO CIRCUMSTANCES SHALL STI BE LIABLE FOR ANY DIRECT, INDIRECT, SPECIAL, INCIDENTAL OR CONSEQUENTIAL DAMAGES OR LOSSES, INCLUDING, WITHOUT LIMITATION, ANY LOSS OF REVENUE, PROFIT OR USE. Prior to use, the user shall determine the suitability of the product for its intended use, and the user assumes all risks and liability for subsequent use. No person other than an officer of STI is authorized to bind STI to any other warranty for any product for which this warranty is issued.

MADE IN THE USA – COPYRIGHT © 2016 SPECIFIED TECHNOLOGIES INC.



Specified Technologies Inc. • Somerville NJ 08876 • Phone: 800.992.1180 • Fax: 908.526.9623

