

Optional Ground Attachment

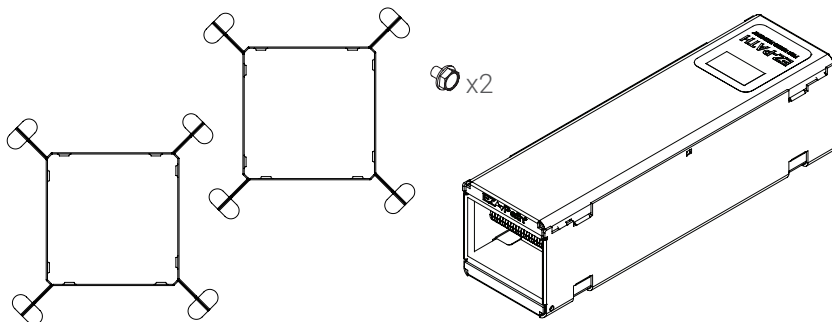

Parts Included (Not to Scale)

Old Work Installations (Cables Already Installed)

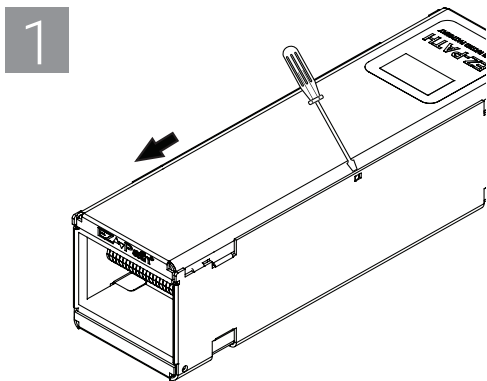

1 Remove lid by placing screw driver into indent on topside of device, sliding lid toward one end of device.

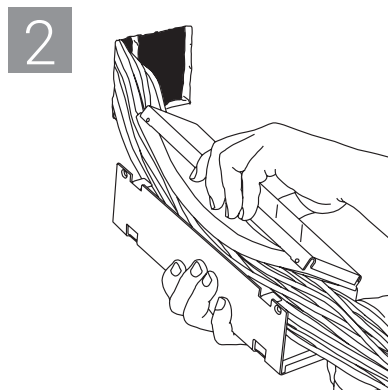

2 Place pathway channel around cables and reinstall device lid.

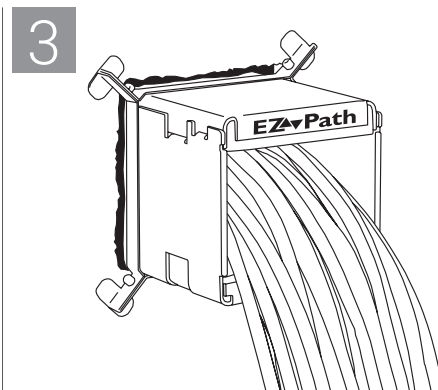

3 Install optional Positioning Clamp (Cat No. EZIP133PC) around cable bundle and slide over pathway making sure that the flat feet of clamp are facing towards wall surface.

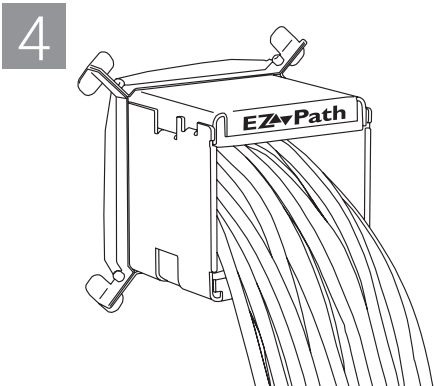

4 Fill annular space between device and wall with approved SpecSeal® Firestop Sealant. See UL System for more detail.

TABLE A: OPENING DIMENIONS

Square/Rectangular	
Opening Height	3-1/8" (79 mm)
Opening Width	3-1/8" (79 mm)
Round	
Opening Diameter	4" (102 mm)

